

aircraft industry parts

MIB Hydro manufactures prototyping and development presses of suitable sizes, according to your specifications. This press allows the manufacture RTM parts, and is also suitable for other processes.

The press is equipped with a movable lower platen, in order to facilitate moulds handlings and the unloading of large size parts.

The plurality of heating and cooling zones provides the temperature uniformity of the platens, and also

of the moulds through their dedicated thermocouples. Traceability of cycles and parts, as well the results analysis is performed by the mean of the supervision management.

The cycle data printing and their backup are integrated in the system.

CHARACTERISTICS

- Force : 200 à 2 000 tonnes.
- Passage et course : 1 000 mm.
- Dimensions utiles des plateaux : 2000 x 2000 mm.
- Température de chauffe : max. 450°C.
- Puissance chauffe installée 400 kW.
- Rampe de chauffe réglable : 1 à 10°C/minute.
- Rampe de refroidissement réglable : 2 à 20°C/minute.
- Circuit de refroidissement 300 kW en boucle fermée constitué d'un échangeur à plaques, d'une cuve tampon de 3000 litres et d'un condenseur de vapeur.
- Certification Directive Machine 2006/42/CE.
- Norme EN NF 289+A1.



Supervision control

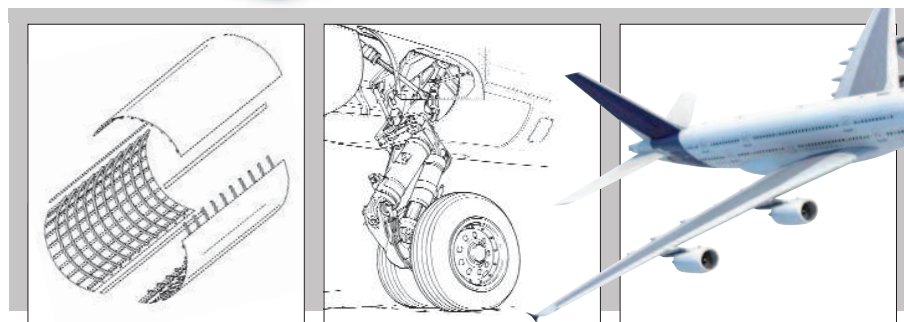

Lower movable platen in

